



HERRALUM®

líder en herrajes para aluminio y vidrio



1 kit

Múltiplo



Características
Especiales

- Compatible con todas las manillas twenty
- Indicador de cerrado y abierto
- Diseño ergonómico para mejor agarre
- Lacado antibacteriano

1382069NE KIT TIRADOR DE APOYO CON COMANDO TWENTY 20°

fapim®
Life in evolution

🇮🇹 Made in Italy

Diseño ergonómico con indicador de cerrado y abierto.

Mod. 5041A.

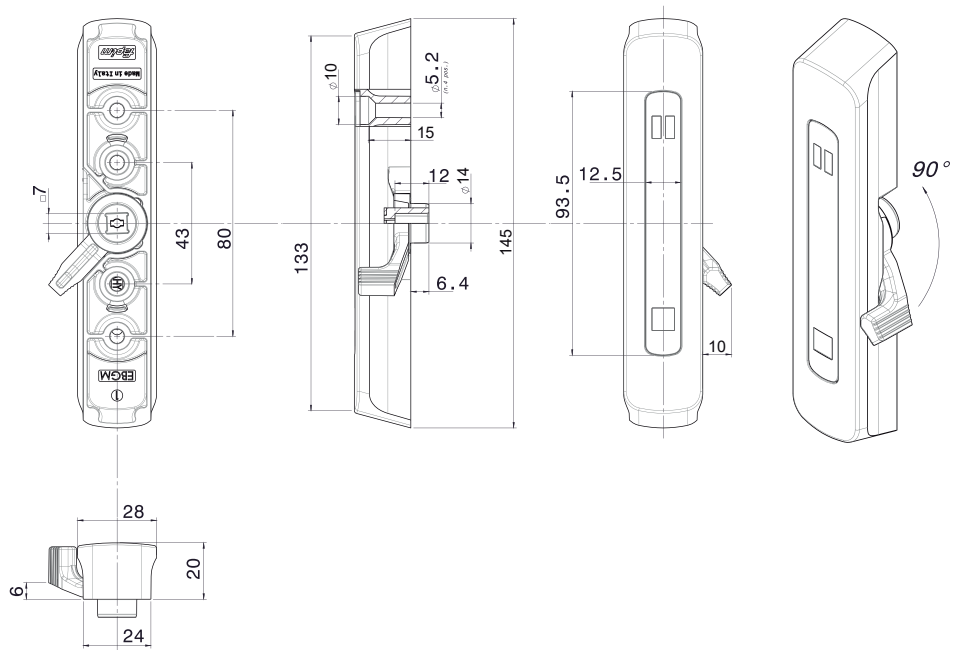

Producto
Reforzado



MINIMALIST



www.herralum.com

DERECHOS RESERVADOS
Herralum Industrial S.A. de C.V.
Calle 4 No.10557 Parque Industrial El Salto
C.P. 45680 El Salto, Jal.
Tel. (33) 3666 0312





HERRALUM®
líder en herrajes para aluminio y vidrio

Instrucciones de instalación

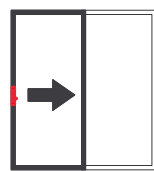
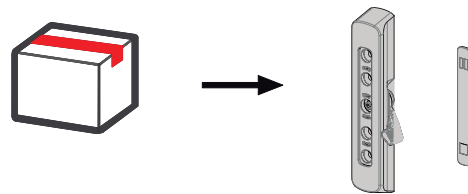

RIGHT

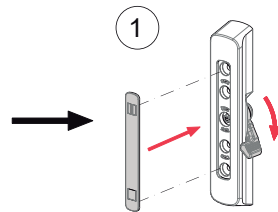

CLIP

2

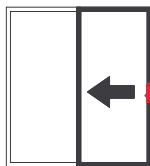
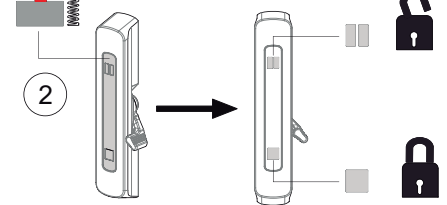

LEFT

1

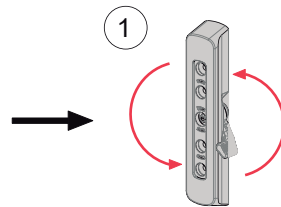

2

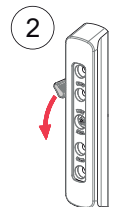

3

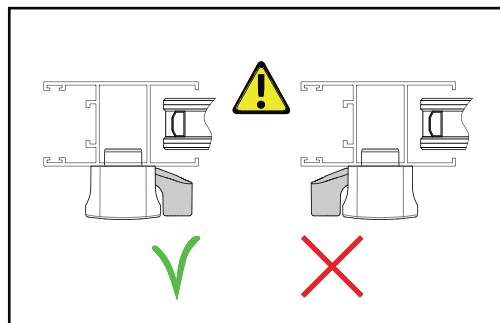
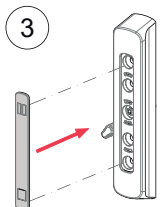

CLIP

4

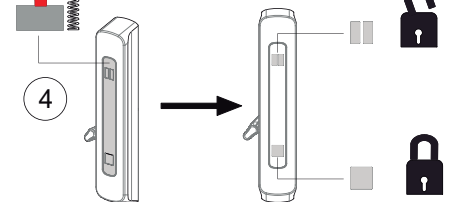

www.herralum.com

DERECHOS RESERVADOS
Herralum Industrial S.A. de C.V.
Calle 4 No.10557 Parque Industrial El Salto
C.P. 45680 El Salto, Jal.
Tel. (33) 3666 0312





HERRALUM®
líder en herrajes para aluminio y vidrio



PERNO CUADRADILLO

fapim®
Life in evolution

Made in Italy



De 7mm con largo de 64mm.
Mod. 5042I.

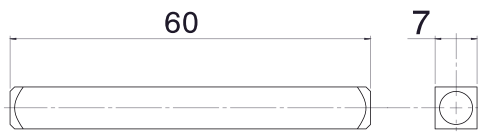

Instalación

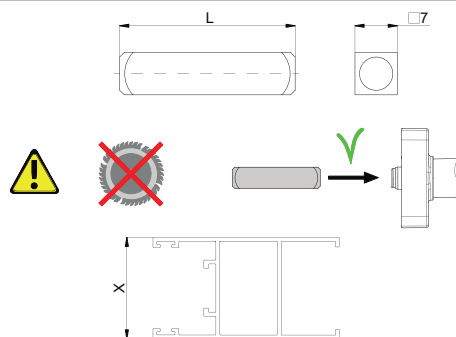

	SINGLE	DOUBLE	DOUBLE
$26 \leq X < 29$	5042A (L=29)	5042C (L=36)	5042A (L=29)
$29 \leq X < 33$	5042B (L=32)	5042D (L=40)	5042B (L=32)
$33 \leq X < 37$	5042C (L=36)	5042E (L=44)	5042C (L=36)
$37 \leq X < 41$	5042D (L=40)	5042F (L=48)	5042D (L=40)
$41 \leq X < 45$	5042E (L=44)	5042G (L=52)	5042E (L=44)
$45 \leq X < 49$	5042F (L=48)	5042H (L=56)	5042F (L=48)
$49 \leq X < 53$	5042G (L=52)	5042I (L=60)	5042G (L=52)
$53 \leq X < 57$	5042H (L=56)	5042J (L=64)	5042H (L=56)
$57 \leq X < 61$	5042I (L=60)		5042I (L=60)
$61 \leq X < 65$	5042J (L=64)		5042J (L=64)

Instalación personalizada

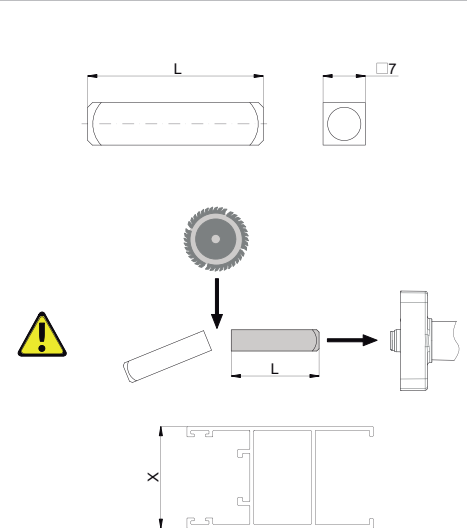

	SINGLE	DOUBLE	DOUBLE
L (mm)	X + 3	X + 10	X + 3



www.herralum.com

DERECHOS RESERVADOS
Herralum Industrial S.A. de C.V.
Calle 4 No.10557 Parque Industrial El Salto
C.P. 45680 El Salto, Jal.
Tel. (33) 3666 0312





HERRALUM®
líder en herrajes para aluminio y vidrio



KIT DE TORNILLOS DE FIJACIÓN AUTOROSCANTE TWENTY 20°

fapim®

Life in evolution

🇮🇹 Made in Italy



Indispensable para instalar
los 5 modelos twenty



Producto
Reforzado

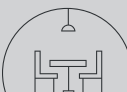

MINIMALIST



www.herralum.com

DERECHOS RESERVADOS
Herralum Industrial S.A. de C.V.
Calle 4 No.10557 Parque Industrial El Salto
C.P. 45680 El Salto, Jal.
Tel. (33) 3666 0312

