



HERRALUM®

líder en herrajes para aluminio y vidrio



1 kit

Múltiplo



Características
Especiales

- Recomendable para chapa 1298 y 1285
- Mangos reforzados
- Diseño recto y minimalista
- Lacado antibacteriano
- Cuerpo de aluminio fundido a presión
- Muelles y arandelas en acero inox

SERIES COMERCIALES
COMPATIBLES



1.75, AB, 45, 50
comercial y residencial
CUPRUM



1.75, 1400
EXTRUSIONES
METÁLICAS



1.75, 2500, 3500
comercial y residencial
INDALUM



1.75 y V40
VALSA

1382061GR DOBLE MANILLA HERA

fapim®

Life in evolution

🇮🇹 Made in Italy

Combina estilo
y protección.

Mod. 2041.

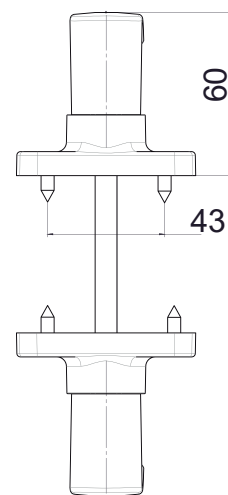
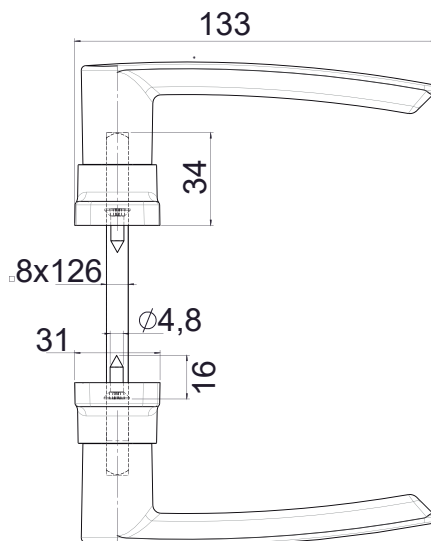
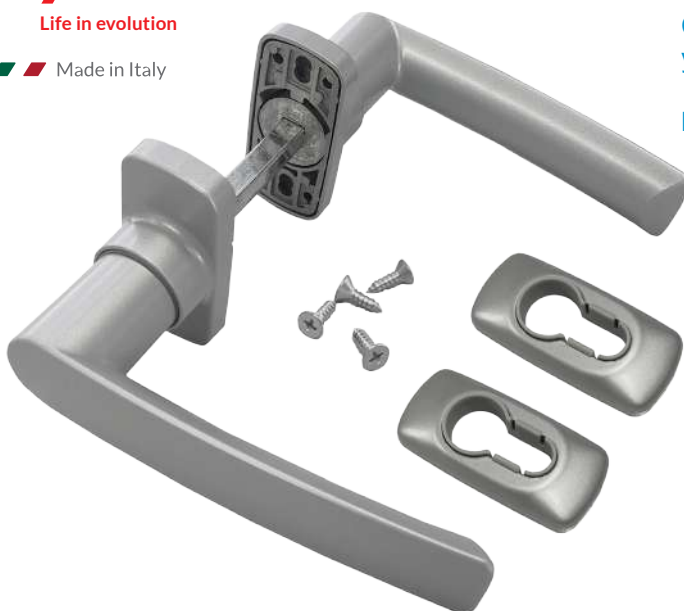

www.herralum.com

DERECHOS RESERVADOS
Herralum Industrial S.A. de C.V.
Calle 4 No.10557 Parque Industrial El Salto
C.P. 45680 El Salto, Jal.
Tel. (33) 3666 0312





HERRALUM®
líder en herrajes para aluminio y vidrio

fapim®

Life in evolution

Made in Italy

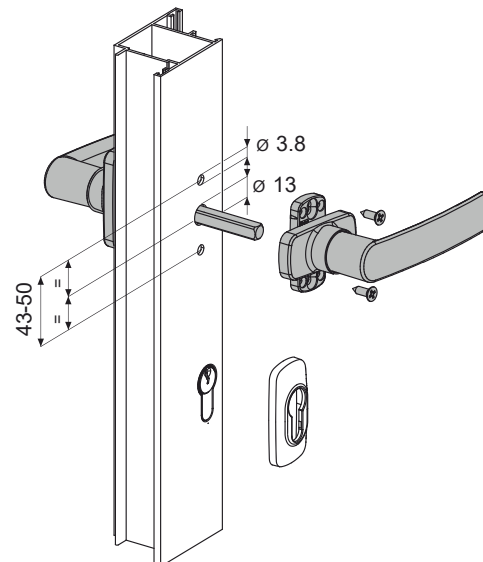
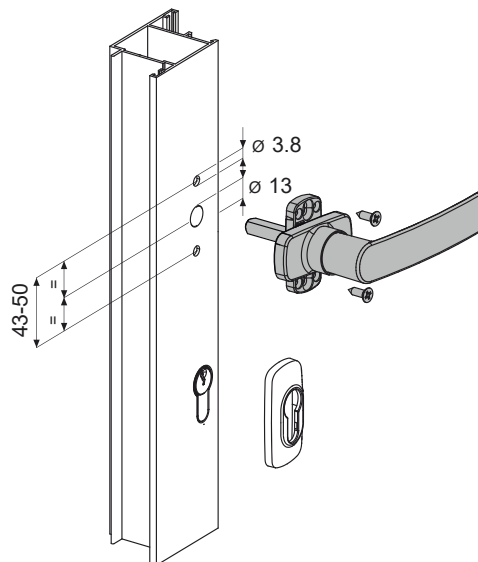
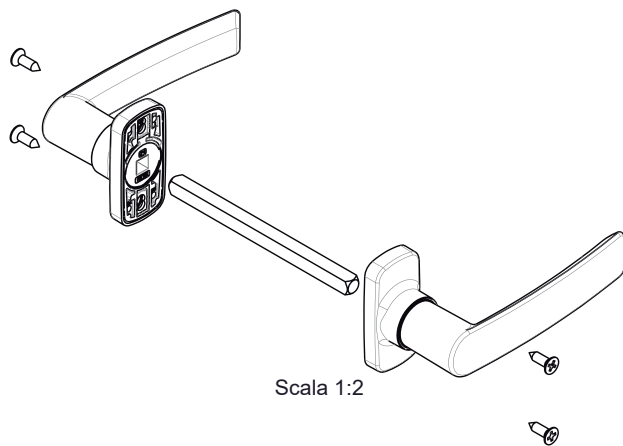
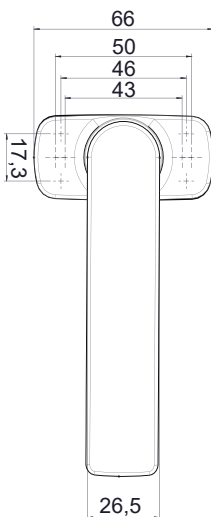

Producto Reforzado



MINIMALIST



www.herralum.com

DERECHOS RESERVADOS
Herralum Industrial S.A. de C.V.
Calle 4 No.10557 Parque Industrial El Salto
C.P. 45680 El Salto, Jal.
Tel. (33) 3666 0312





HERRALUM®

líder en herrajes para aluminio y vidrio



Múltiplo

El kit incluye
2 piezas

SERIES COMERCIALES
COMPATIBLES



1.75, AB, 45, 50
comercial y residencial
CUPRUM



1.75, 1400
EXTRUSIONES
METÁLICAS



1.75, 2500, 3500
comercial y residencial
INDALUM



1.75 y V40
VALSA



Producto
Reforzado

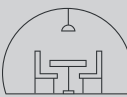

MINIMALIST

PLACA CUBRE CILINDRO

fapim®

Life in evolution

🇮🇹 Made in Italy



Europeo de aluminio
que se usa en conjunto
a la 1382061.

Mod. 2100.

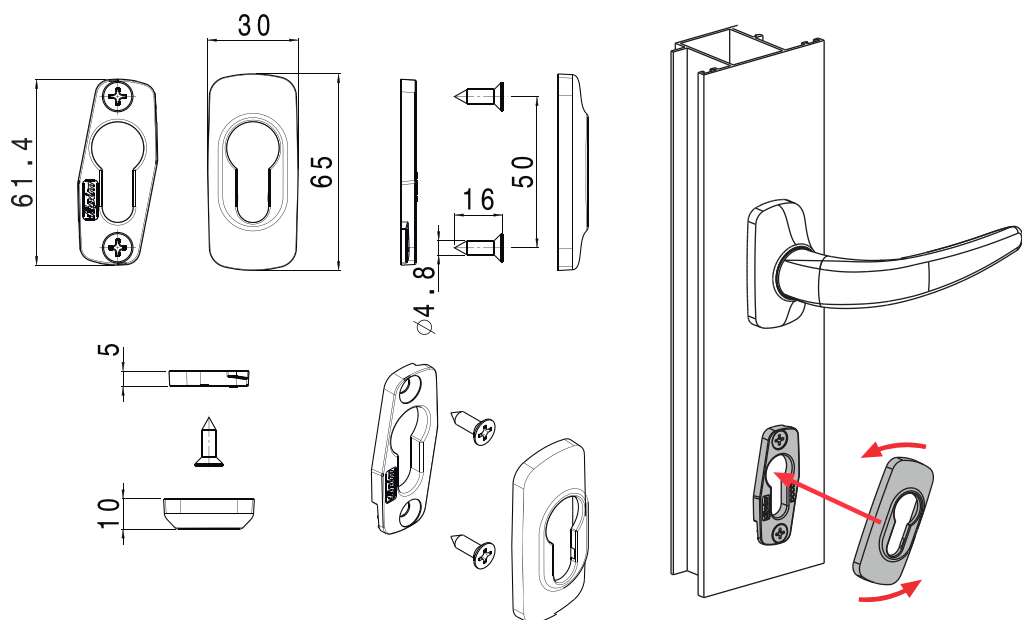

www.herralum.com

DERECHOS RESERVADOS
Herralum Industrial S.A. de C.V.
Calle 4 No.10557 Parque Industrial El Salto
C.P. 45680 El Salto, Jal.
Tel. (33) 3666 0312

